

# Technical Manual

# JBL SRX725/F



## SPECIFICATIONS

### ACOUSTIC & ELECTRICAL SPECIFICATIONS:

- Nominal Impedance: 4 Ohms
- Power Capacity: Continuous Program / Peak:  
Passive: 1200W / 2400W / 4800W  
Bi-amp L.F: 1200W / 2400W / 4800W  
Bi-amp H.F: 75W / 150W / 300W
- Frequency Range: 37 Hz – 20 kHz (–10 dB)
- Maximum SPL: 136 dB SPL peak  
L.F. 134 dB SPL cont avg (140 dB peak)  
H.F. 133 dB SPL cont avg (139 dB peak)  
Passive mode: 134 dB SPL cont avg (140 dB peak)
- System Sensitivity: Passive Mode 99 dB SPL (1 watt @ 1 meter)
- Passive Crossover: Bi-am / passive, externally switchable  
HP and LP, 1.2 kHz

### SYSTEM COMPONENTS:

- Cabinet: Enclosure (Not For Sale)
- Grille: 353310-002
- Low Frequency Transducer: 2 2265HPL, 380 mm (15 in) Differential Driver woofer with neodymium-magnet & dual voice coils
- DC Resistance: 4 ohms
- High Frequency: 2453H, 102 mm (4 in) voice coil, neodymium-

### SYSTEM COMPONENTS: (CONT'D)

- Transducer: magnet compression driver
- DC Resistance: 4.1 ohms ± 8%
- Crossover Network: 353342-002

### AURAL SWEEP TEST SPECIFICATIONS:

- A. System Aural Sweep Test: 10.0V Input, 20 Hz to 20 kHz
- B. L.F. Aural Sweep Test: 15.0V Input, 10 Hz to 100 kHz
- C. H.F. Aural Sweep Test: 2.83V Input, 550 Hz to 20 kHz

### PHYSICAL SPECIFICATIONS:

- Enclosure Dimensions: 1219 x 541 x 508 mm D (48.0 x 21.3 x 27.20 in. D)
- Net Weight: 100 lb (45 kg.)

### WARRANTY INFORMATION:

- Refer to Warranty Statement packed with each product.

\* SRX725 starting with serial number SRX725-15053.

\* SRX725F on all models manufactured after 2005

## PACKAGE

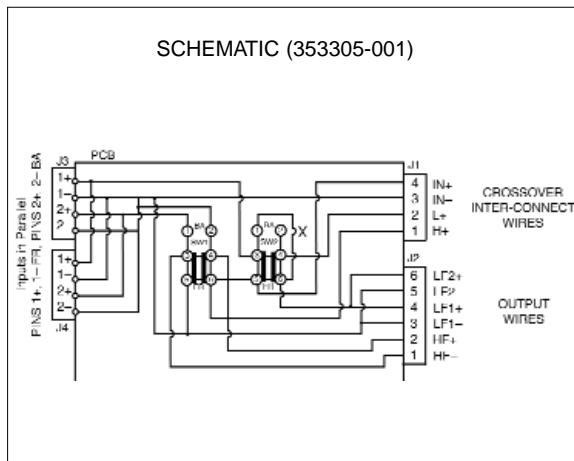
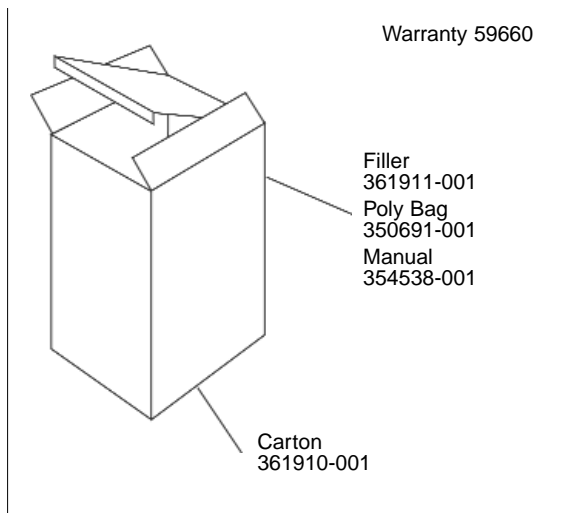

## WIRING DIAGRAM

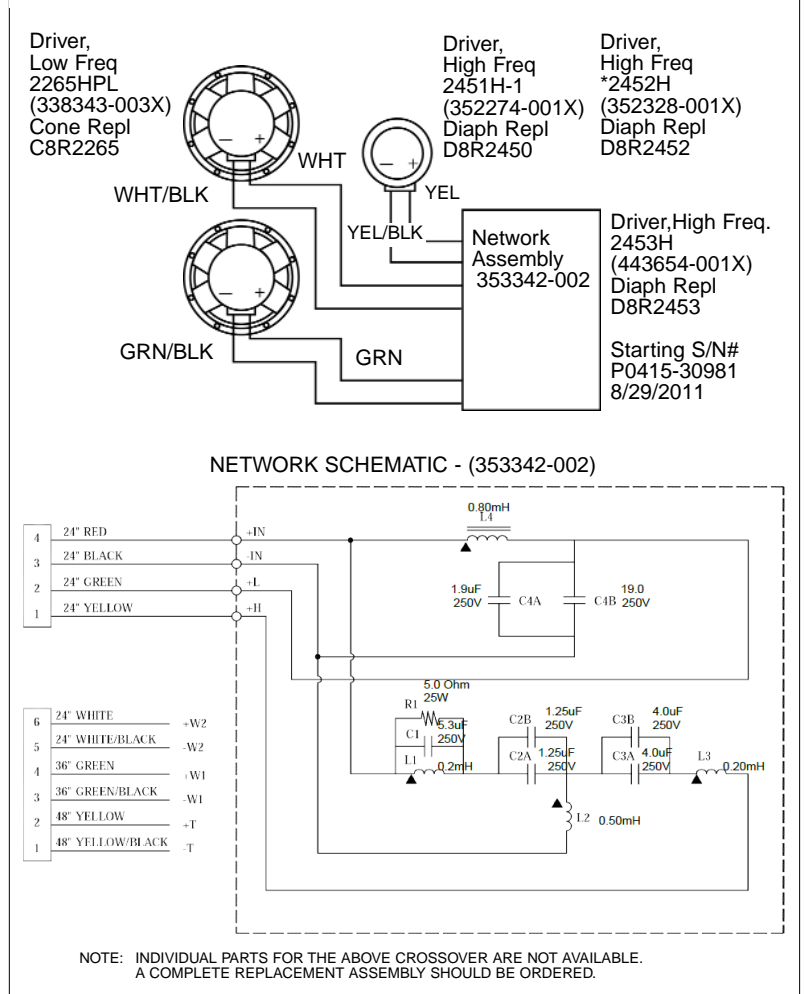

JBL SRX725/F REV

# JBL SRX725/F

## COMPONENT EXPLODED VIEW

